

# GROUP 17

## CONTENTS

[ LIMITED SLIP DIFFERENTIAL . . . . .	17-1/1	AXLE SHAFT - SERVICE DATA	
DIFFERENTIAL - SERVICE DATA		AND SPECIFICATIONS . . . . .	17-7
AND SPECIFICATIONS . . . . .	17-2	General specifications . . . . .	17-7
Technical data . . . . .	17-2	Tightening torques . . . . .	17-7
General specifications . . . . .	17-2	SPECIAL SERVICE TOOLS . . . . .	17-8
Checks and adjustments . . . . .	17-3		
Tightening torques . . . . .	17-6		

See Supplement Starting Next Page

# LIMITED SLIP DIFFERENTIAL

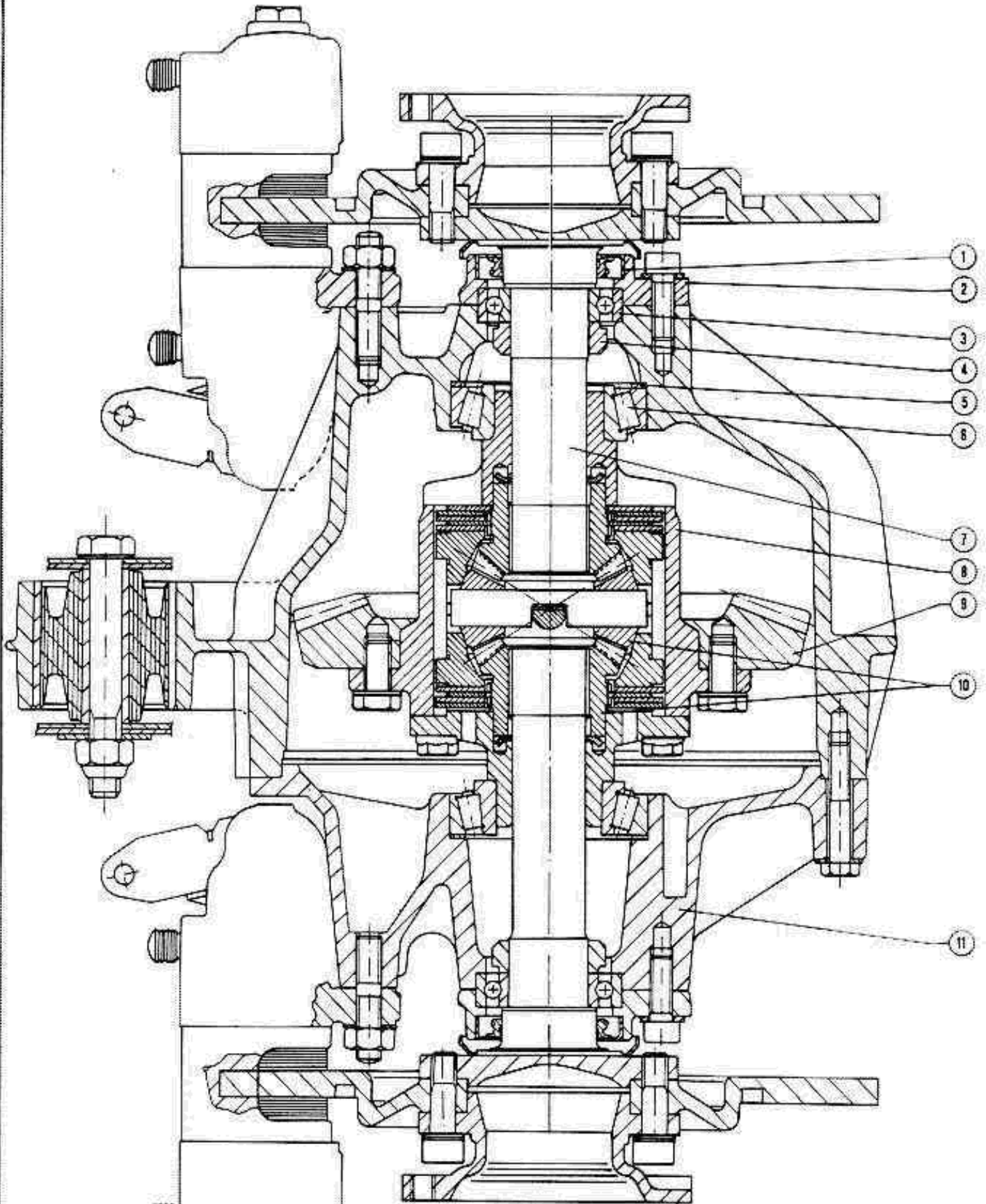

- |  |                                      |
|--|--------------------------------------|
| 1 Oil seal ring                                    | 6 Differential carrier taper bearing |
| 2 Cover  | 7 Differential internal drive shaft  |
| 3 Differential internal drive shaft bearing        | 8 Differential carrier               |
| 4 Bearing ring nut                                 | 9 Ring bevel gear                    |
| 5 Shim ring for differential carrier taper bearing | 10 Side pinions-crown wheels gears   |
|  | 11 Differential-speed gear casing    |

# DIFFERENTIAL AND AXLE SHAFT UNIT

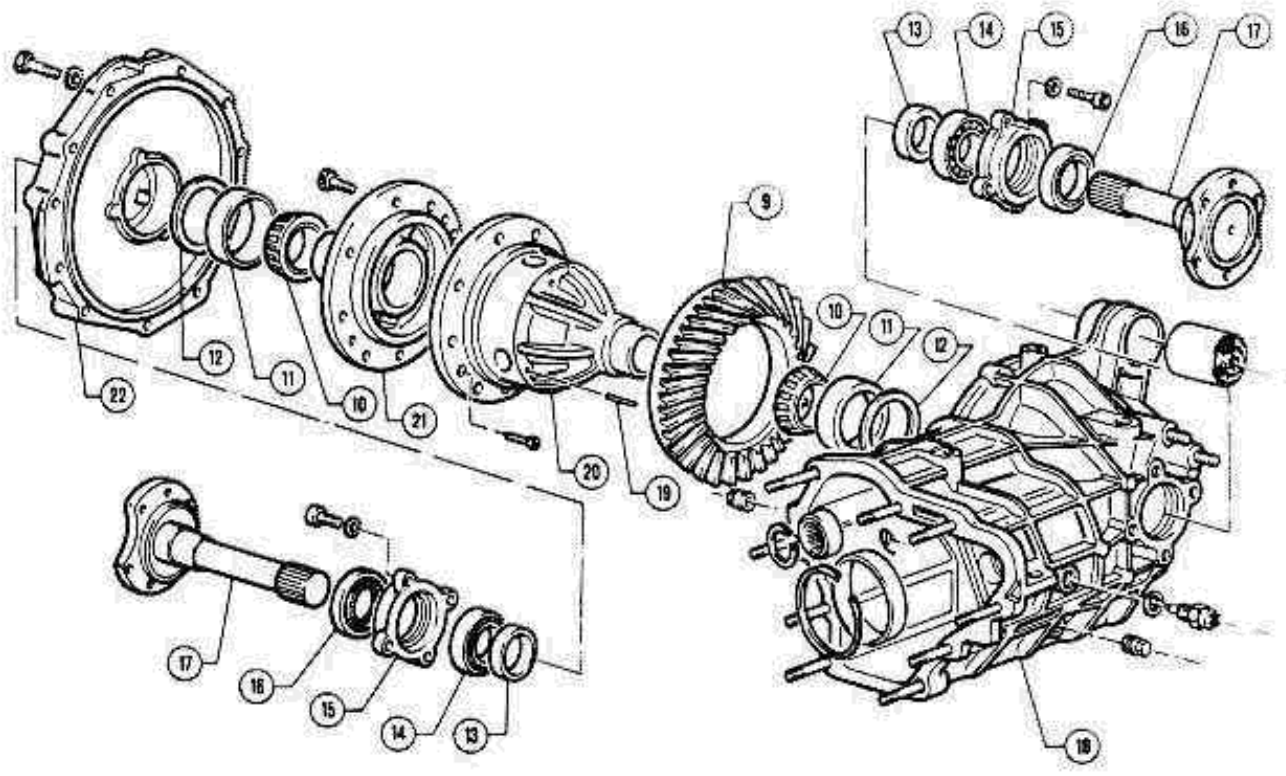
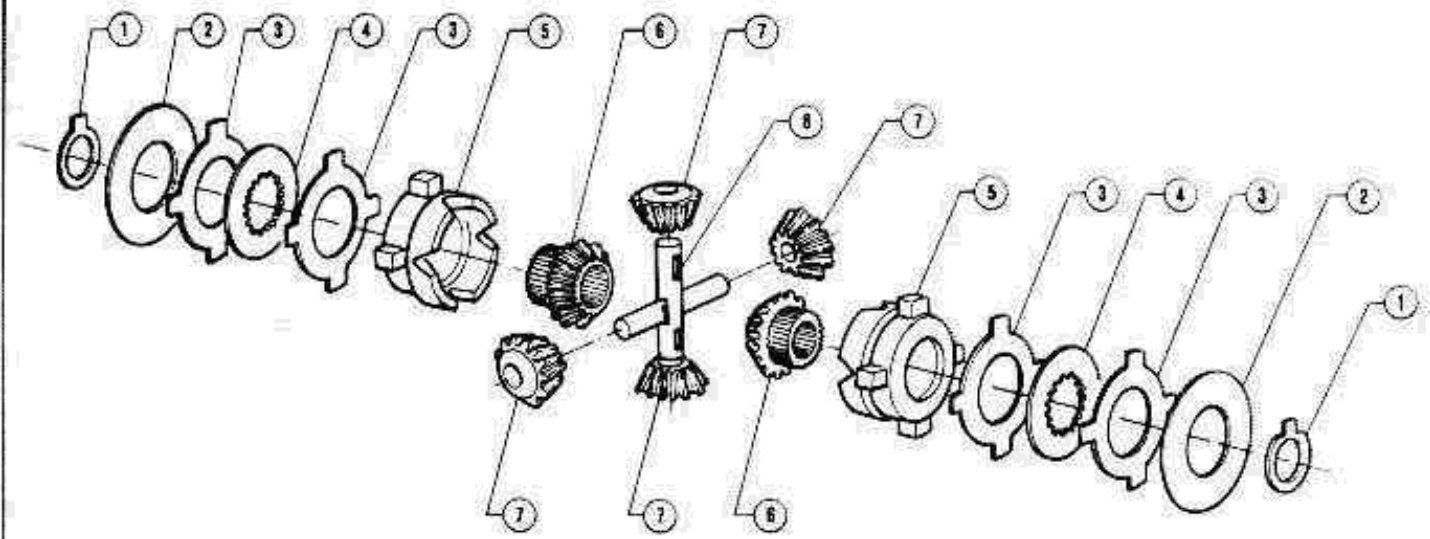

- 1 Stop ring
- 2 Spacer
- 3 External blade
- 4 Internal blade
- 5 Pressure ring
- 6 Side gear
- 7 Pinion gear
- 8 Pin
- 9 Ring bevel gear
- 10 Differential carrier taper bearing
- 11 Differential carrier taper bearing external race

- 12 Differential carrier taper bearing shirn ring
- 13 Bearing ring nut
- 14 Bearing of differential internal drive shaft
- 15 Cover
- 16 Oil seal ring
- 17 Differential internal drive shaft
- 18 Differential-speed gear casing
- 19 Spring pin
- 20 Differential carrier
- 21 Differential casing cover
- 22 Differential-speed gear casing cover

# DIFFERENTIAL-SERVICE DATA AND SPECIFICATIONS

## TECHNICAL DATA

Refer to Group 13 - "Service Data and Specifications - Technical Data".

## GENERAL SPECIFICATIONS

### FLUIDS AND LUBRICANTS

Application	Type	Denomination	Q.ty
Differential roller bearing	GREASE	AGIP Grease 33 FD IP Autogrease FD SHELL Retinax AX ESSO Norva 275 (Std. No. 3671-69833)	—
Outer rings of differential taper bearing			—
Threading of screws securing axle shaft to differential shaft	GREASE	ISECO Molykote BR2 (Std.No. 3671-69841)	—
Spherical seat of propeller shaft rear joint			—
Internal lip of seal rings			5 cm <sup>3</sup> (0.30 cuin)
Filling of differential-speed gear casing	OIL	AGIP Rotra MP SX SAE 75W/90 SHELL Spirax HD 80W/90 IP Pontiac HDS SAE 75W/90 (Std. No. 3631-69412)	4.56 lb (2.070 kg)
Outer surface of seal rings			—

### SEALANTS AND SURFACE FIXING AGENTS

Application	Type	Denomination	Q.ty
Mating surface of axle shafts-covers	SEALING COMPOUND	LOWAC Perfect Seal (Std. No. 3522-00011)	—

**CHECKS AND ADJUSTMENTS**

Type of differential	Four side pinions	
<b>Application</b>		
Installation clearance between side pinions and crown wheels teeth	G mm (in)	0.08 to 0.15 (0.003 to 0.006)

Shim washer correction shim "S" between 4th speed engagement bush and bearing internal ring.

$$S = \pm L (\pm C)$$

where:

- L = Deviation value of ring bevel gear axis measured with centesimal gauge
- C = Value marked on pinion head

The real dimension must correspond to the nominal dimension of the algebraic value marked on pinion head (in hundredths)

T = Pinion head height

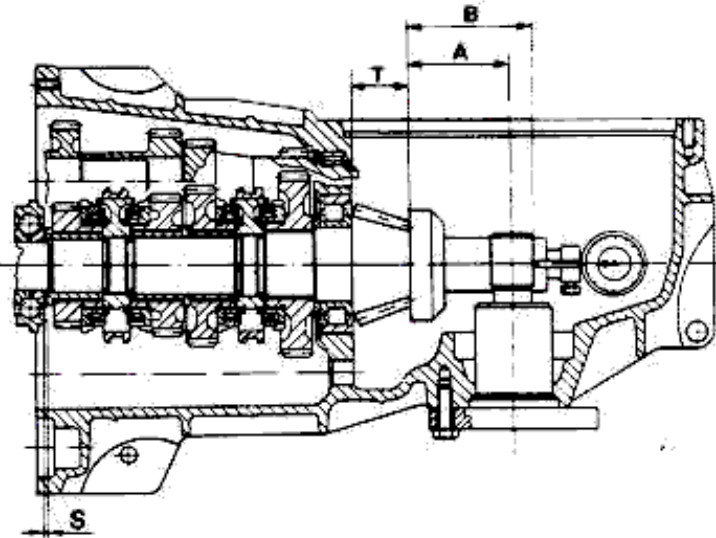

Pinion type	Pinion head height T = 36 mm (1.42 in)	
<b>Application</b>		
Nominal dimension between ring bevel gear axis and pinion head	A mm (in)	62.6 ± 0.03 (2.46 ± 0.001)
Dimension of tool C.6.0164 for gauge resetting	B mm (in)	72.6 (2.86)
Installation clearance between ring bevel gear and pinion	G mm (in)	0.10 to 0.20 (0.004 to 0.008)

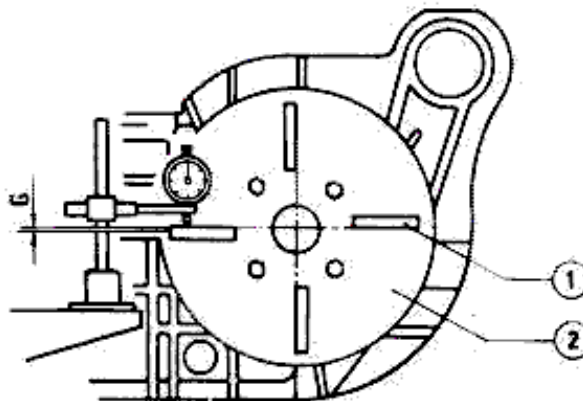

- 1 Graded spoke
- 2 Tool sheave

Ring bevel gear average radius	R mm (in)	77 (3.03)
--------------------------------	-----------	-----------

# DIFFERENTIAL AND AXLE SHAFT UNIT

Clearance between splined section of axle shafts and differential crown wheels G mm (in)	0.07 to 0.13 (0.00275 to 0.0051)
Squareness deviation of brake disk support plane with respect to bearing and oil seal ring seats S mm (in)	0.05 (0.00197)
Installation interference fit for axle shaft bearing retaining ring nut I mm (in)	0.023 to 0.057 (0.0009 to 0.0022)

## SHIM RINGS

### Shims "S" for pinion - ring gear axis

Minimum shim  
 $S_{min} = 0.08 \text{ mm}$

The remaining shims increase progressively by 0.05 mm each time, starting from 1.15 mm up to 2.50 mm.

### Shims "S" for preload of the differential casing bearings.

The shims increase progressively by 0.25 each time, starting from 1.350 mm up to 2.600 mm.

## HEATING TEMPERATURES

Application	Measurement Unit	°C (°F)
Differential shaft bearing ring nut		190 (374)

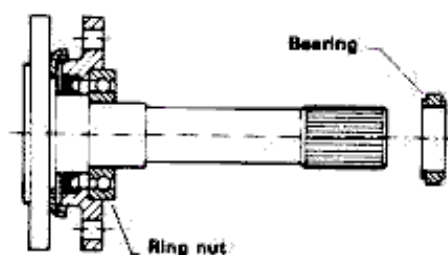

## ROLLING TORQUES

Item	Measurement Unit	N-cm (ft-lb; kg-cm)
Differential carrier (to determine static preload of taper bearings)		
— Re-used bearings		49 to 68 (0.36 to 0.51; 5 to 7)
— New bearings		98 to 196 (0.72 to 1.45; 10 to 20)



**LIMITED SLIP DIFFERENTIAL**

Fitment clearance between cover and pack of segments

$$G = A - B = 0.1 \text{ thru } 0.2 \text{ mm}$$

$$(0.004 \text{ thru } 0.008 \text{ in})$$

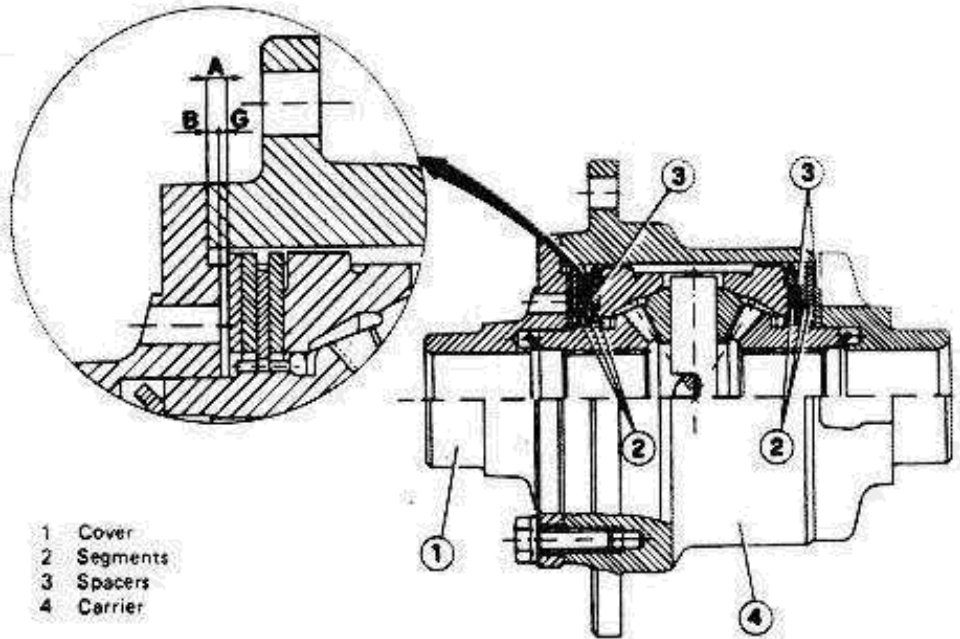

- 1 Cover
- 2 Segments
- 3 Spacers
- 4 Carrier

To check that clearance G is within the specified tolerances, proceed as follows:

1. Rest the supporting base of a suitably preloaded dial gauge on the contact surface ② between cover ① and segment pack, by operating on the cover of the limited slip differential carrier; zero set the dial gauge on the mating surface ③ between cover and carrier.

2. Position the gauge supporting base on the mating surface ① between carrier ② and cover by operating on the limited slip differential carrier; have the gauge feeler contacting segment pack ③.

3. Read the value, with negative sign, of clearance G; it must be within the specified values.

**Fitment clearance between cover and segment pack:**

$$G = 0.1 \text{ thru } 0.2 \text{ mm}$$

$$(0.004 \text{ thru } 0.008 \text{ in})$$

4. Should clearance G be out of specified limits, replace the spacers with others of suitable thickness.

**NOTE:**

Apply a load of 10 Kg (22 lbs) to the segment pack.

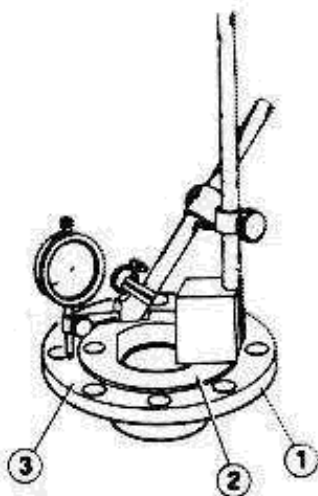

- 1 Cover
- 2 Cover-segment pack contact surface
- 3 Cover-carrier mating surface

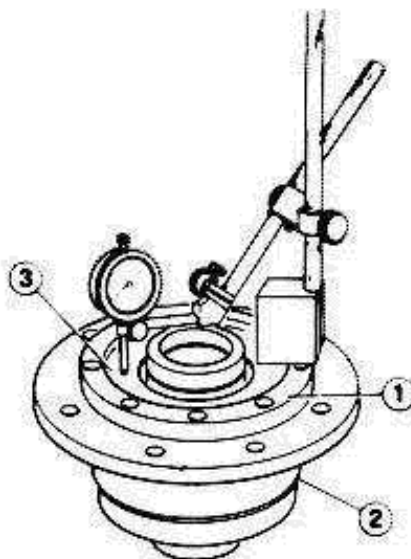

- 1 Carrier-cover mating surface
- 2 Carrier
- 3 Segment pack

**TIGHTENING TORQUES**

Description	Measurement unit	N·m (ft·lb; kg·m)
Screws securing spacers and brake discs to internal axle shafts		49 to 54 (36.1 to 39.8; 5 to 5.5)
Screws securing propeller shaft joint to clutch shaft fork		55 to 57 (40.5 to 41.9; 5.6 to 5.8)
Screws securing external axle shafts to internal axle shafts (1)		44 to 54 (32.5 to 39.8; 4.5 to 5.5)
Screws securing covers to differential speed gear casing		18 to 21 (13.0 to 15.9; 1.8 to 2.2)
Screws securing ring bevel gear to differential carrier (in oil)		67 to 74 (49.2 to 54.2; 6.8 to 7.5)
Pinion shaft securing nut		112 to 124 (82.4 to 91.1; 11.4 to 12.6)
Nut securing spacers and intermediate flange to differential-speed gear casing		112 to 124 (82.4 to 91.1; 11.4 to 12.6)
Securing screws of differential speed gear casing cover		19 to 23 (13.7 to 16.6; 1.9 to 2.3)
Nuts securing brakes calipers to differential-speed gear casing		45 to 52 (33.3 to 38.3; 4.6 to 5.3)
Unions of brakes and clutch control system piping: — Pipes — Hoses		8 to 10 (5.8 to 7.2; 0.8 to 1) 10 to 15 (7.2 to 10.8; 1 to 1.5)
Reverse speed engagement indicator switch (on speed gear-differential casing)		23 to 26 (16.6 to 19.5; 2.3 to 2.7)
Nut securing plate for reverse speed engagement safety device		8.3 to 10.3 (6.5 to 7.6; 0.9 to 1.05)
Bolt securing rear support rubber bushing of clutch-speed gear-differential unit		71 to 89 (52.1 to 64.3; 7.2 to 8.9)
Screws securing speed gear-differential unit to lateral support small block		18.6 to 23.5 (13.7 to 17.4; 1.9 to 2.4)

(1) Use the grease prescribed: ISECO Molykote BR2



**AXLE SHAFT-SERVICE DATA AND SPECIFICATIONS****GENERAL SPECIFICATIONS****FLUIDS AND LUBRICANTS**

Description	Type	Recommended product	Quantity
Axle shaft screw thread	GREASE	ISECO: Molykote BR2 Part No. 3671-69841	—
Axle shaft constant velocity U-joint  Apply an equal amount of grease on both sides of row of balls	GREASE	ISECO: Molykote VN2461C OPTIMOL: Olystamoly 2LN584 Part No. 3671-69843	120 g (4.23 oz.)

**SEALANTS**

Description	Type	Recommended product
C. V. U-joint inner and outer cover surface	Jointing compound	DIRING: Curil K2 Part No. 3522-00031
C.V. U-joint inner cover and bellows surface	Jointing compound	BOSTON: Bostik 475 U.S.M. 475 Part No. 3521-00034







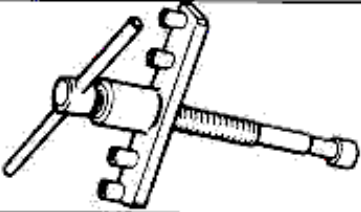

**TIGHTENING TORQUES**

Description	Measurement unit	N·m (ft·lb; kg·m)
Capscrews, axle shaft to differential and wheel shaft		44 to 54 (32.5 to 39.8; 4.5 to 5.5)
Capscrews, axle shaft to spacer and wheel shaft		

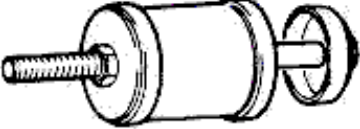
# SPECIAL SERVICE TOOLS

Tool Number	Tool name	Page Ref.
A.2.0175	Spacer for locking pinion shaft to intermediate flange (to be used with A.2.0250)	-
A.2.0247	Plate for removing retaining ring nut of differential internal axle shaft bearing.	-
A.2.0248	Plate for removing differential internal axle shaft.	-
A.2.0250	Tool for locking pinion shaft (to be used with A.2.0175)	-
A.2.0267	Dummy rods for striking rod balls and speed engagement detent balls.	-
A.3.0272	Driver for internal and external rings of differential carrier taper bearings.	-
A.3.0287	Adjustable span puller for differential carrier taper bearing inner races.	-

# DIFFERENTIAL AND AXLE SHAFT UNIT

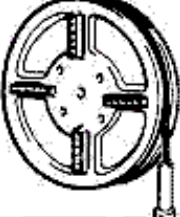
Tool Number	Tool name	Page Ref.
A.3.0348	Puller-driver for outer race of pinion shaft rear roller bearing (to be used with A.3.0593) 	-
A.3.0412	Driver for insertion of bearing and ring nut on differential internal axle shaft 	-
A.3.0413	Puller-driver of rear rubber bushing securing clutch-speed gear-differential unit to body 	-
A.3.0430	Driver for insertion of oil seal ring on differential internal axle shaft covers 	-
A.3.0593	Bushing for pulling and driving outer race of pinion shaft rear roller bearing (to be used with A.3.0348) 	-
A.4.0196	Support of dial gauge for pinion setting (to be used with C.6.0164 and C.6.0163) 	-
C.2.0037-100/2000	Weights for checking bearings preload n.7 items - (to be used with C.5.0124, C.5.0123 and C.5.0125) 	-
C.5.0123	Tool for checking preload of differential casing bearings (to be used with C.5.0124, C.2.0037 and C.5.0125) 	-
C.5.0124	Sheave for checking preload of differential casing bearings (to be used with C.5.0123, C.2.0037 and C.5.0125) 	-

# DIFFERENTIAL AND AXLE SHAFT UNIT

Tool Number	Tool name	Page Ref.
C.5.0125	Spring bush for checking preload of differential casing bearings (to be used with C.5.0123, C.5.0124 and C.2.0037)	
C.6.0164	Tool for checking pinion position	
C.6.0193	Reference gauge for resetting of pinion position check centesimal gauge (to be used with A.4.0136)	

